

100043x2

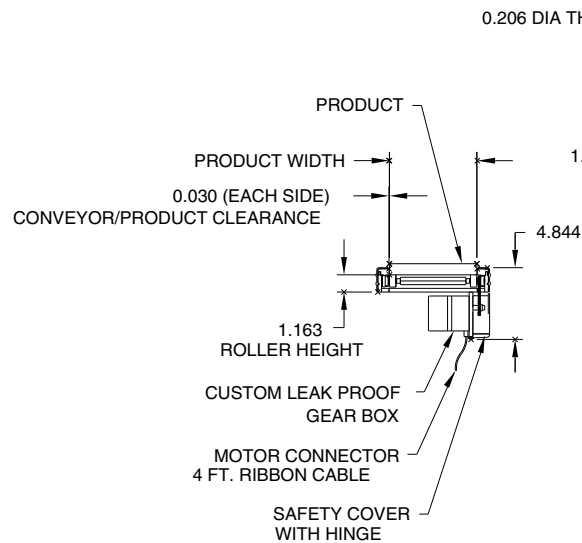

CONVEYOR LENGTH	DIM "A"
MR960	4.500
MR948	4.500
MR939	4.500
MR935	4.000
MR930	4.500
MR922	5.000
MR917	4.000
MR911	4.000

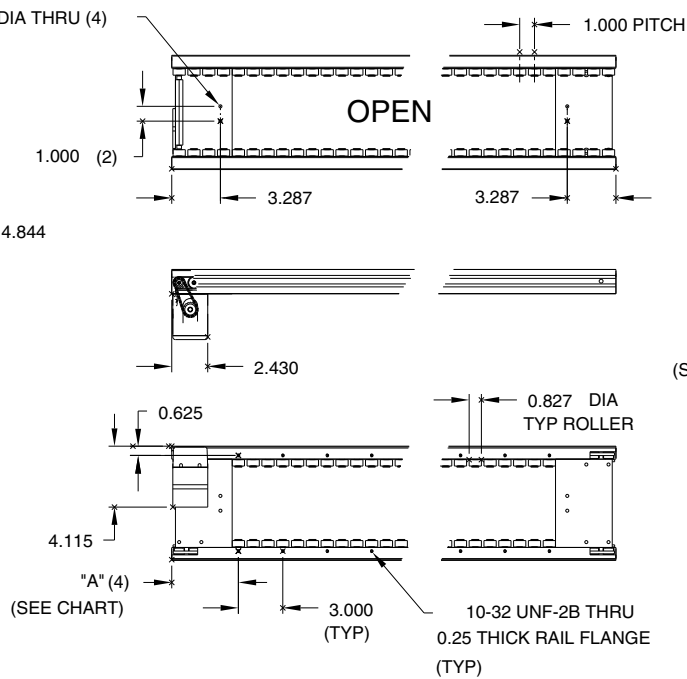

NOTES:

- FOR OPTIONAL DUST COVERS, PART NUMBER ASSIGNMENTS MUST BE MADE FOR EXTENDED SIDE COVER, LEXAN COVER, AND GAP COVER

