

Quickdraw®

CONVEYOR SYSTEMS by MAGSTAR™ TECHNOLOGIES

Connecting Your Workplace

Quickdraw® designs and manufactures conveyor systems for factory automation. A full line of modular components, both standard and custom, are ideal for micro-electronics, automotive sub-assemblies, medical, laboratory, semiconductor, and many other applications. Headquartered in Hopkins, Minnesota, the company serves both domestic and international markets.

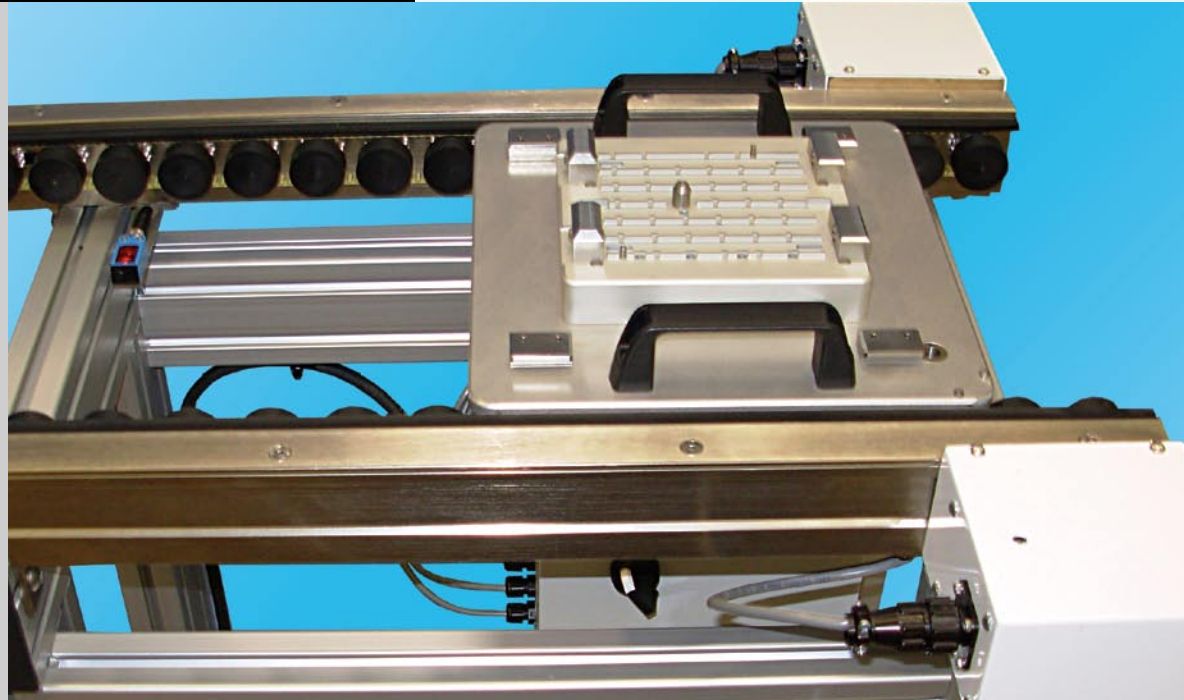

XR SERIES

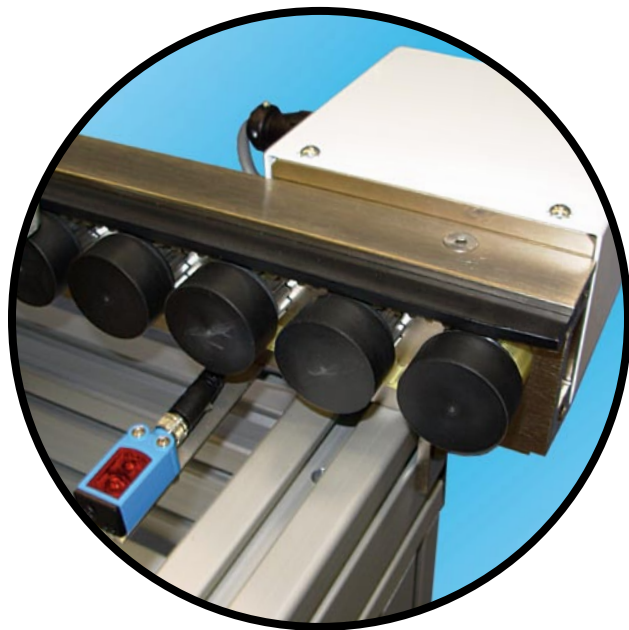

The **XR Series** bridges the capacity gap between the Quickdraw MR Series and HD Series, and is easily configured and integrated into new or existing production lines. Like all Quickdraw conveyors, the XR's proprietary design is modular and sectional, with clean, quiet, and ESD safe operation. The XR also features bidirectional operation with an open center, slip-roller for accumulation, and precise product movement. This low-profile conveyor can be integrated with auxiliary devices such as: Lift & Locate Docks, Rotators, Loaders/Unloaders, Stackers, and Diverter.

Quickdraw®

CONVEYOR SYSTEMS by MAGSTAR™ TECHNOLOGIES

Connecting Your Workplace

XR SERIES

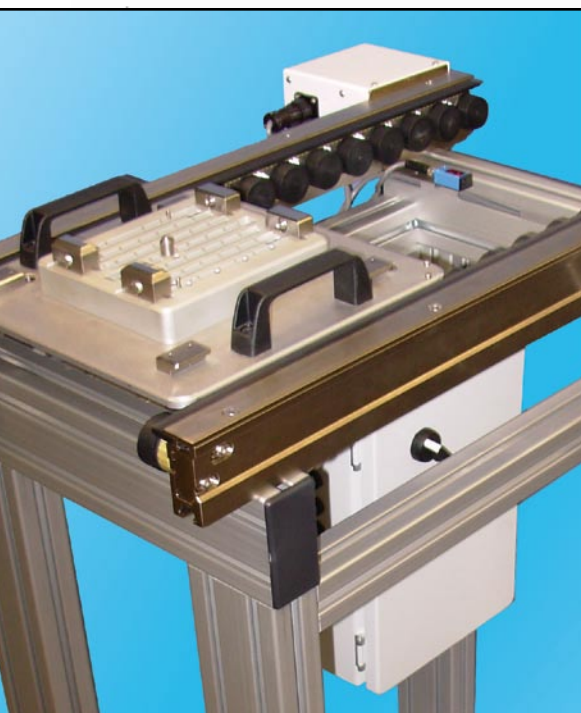
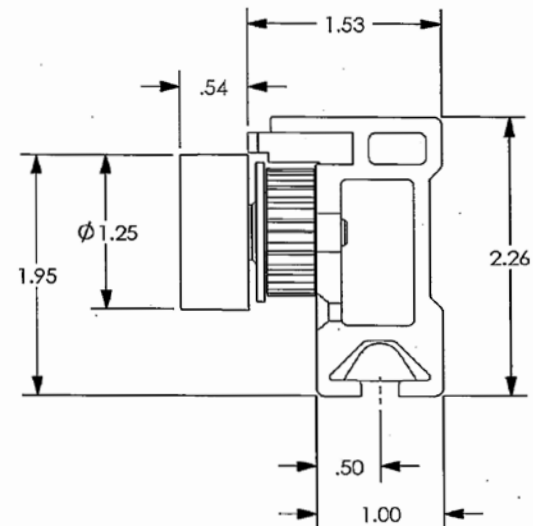
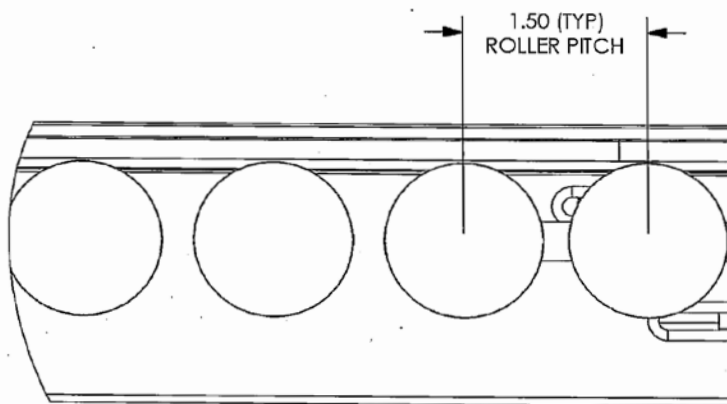

Speed	0–60 feet per minute
Pallet or Part Weight	Minimum: N/A Maximum: Static 60 lbs., Dynamic 120 lbs.
Conveyor Lengths	Up to 120" Custom available in 1.5" increments
Power Requirements	24 VDC. 110 plug & play available
Integrate with	Dispensing, Inspection, Analyzers, Labeling, Shakers
Features	Bidirectional ESD Capacity to accumulate pallets Modular Low profile
Auxiliary Devices	Lift & Locate Docks Rotators Loaders/Unloaders Stackers Diverters